

Getting started

Thank you for purchasing a *Logic Rail Technologies* product! Please read all instructions prior to installing this board. You're probably wondering why such a relatively simple product like this needs FOUR pages of instructions! We have two reasons. First, the *Signal Animator* is extremely versatile and can be used with a wide variety of signals. Second, we'd rather provide you with too much information rather than not enough!

The *Signal Animator* provides automatic operation of 3-color block signals in a semi-prototypical way. An Infrared (IR) emitter and detector are used for train detection. Detection is achieved when the IR beam from the emitter reflects off the underside of the train back down to the detector. **Despite the use of infrared components you could still encounter false triggering from overhead lighting. This is usually eliminated with angled sensor mounting and/or proper sensor sensitivity adjustment (page 3).** This version of the *Signal Animator* must be powered from either a 7-9V AC or 9-12V DC power source. Do NOT exceed these limits! Whenever the sensor is activated by any portion of a train the signal will turn red. Once the sensor is cleared the *Signal Animator* will delay (10 or 30 seconds; see below) and then change the signal to yellow. After another delay the signal will be changed to green.

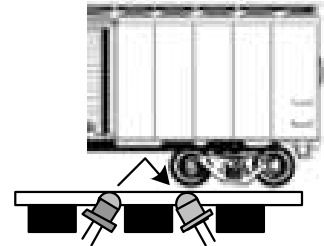

This version of the *Signal Animator* (model SA-1) provides 3-color signaling for LED-based 3-light (common anode/positive) and searchlight-style signals. The signal outputs are "active low" (~ 0 volts when on) and capable of handling 20mA per output.

You should make all of the connections to the *Signal Animator* before applying power to it. You can mount the *Signal Animator* anywhere it is convenient underneath your layout using the four mounting holes provided. The holes will accept #4 screws; do not enlarge the holes as damage to the circuit board can result and your warranty will be voided!

2-lead/3-lead LED Searchlight Signals (older Tomar Industries, Oregon Rail Supply, etc)

To select a searchlight signal on the *Signal Animator* you must have the "jumper" installed over both pins on the "block" labeled "SIG" on the circuit board. This is illustrated in Figure 1. The LED used in SOME model searchlight signals is commonly called a bipolar or tri-color LED. This type of LED has two elements inside of a single housing; one element is green and the other is red. There are two ways that these LEDs are internally wired. One has two leads and the other has three leads; the three-leaded variety is the most common. The *Signal Animator* supports either one as shown in Figures 2a & 2b. You MUST use resistors with LED-based signals! Because the *Signal Animator* provides +5V power to the LED we recommend a resistor value of 150 ohms. We have included three resistors with this product.



Figure 1 – selecting searchlight signals

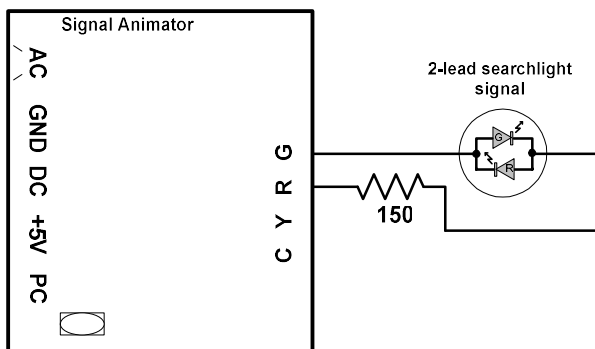

Figure 2a – 2-lead searchlight signal

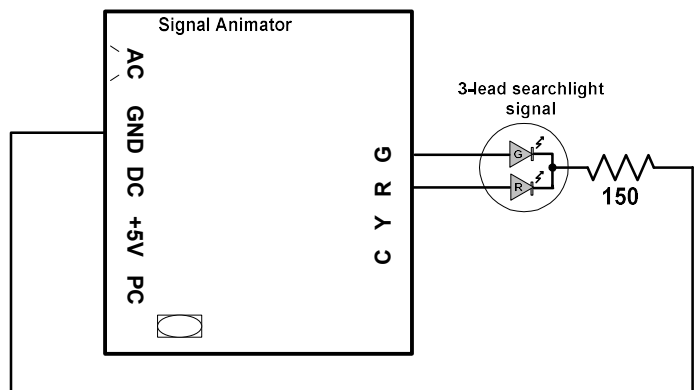

Figure 2b – 3-lead searchlight signal

You can adjust the yellow hue on an LED searchlight signal using the jumper on the block labeled "HUE" on the circuit board. If the jumper covers the top two pins then the yellow hue will be more reddish and less green; if the jumper covers the bottom two pins then the yellow hue will be more greenish and less red. You must choose one or the other! This is illustrated in Figure 3.

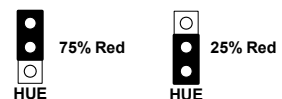

Figure 3 – adjusting yellow hue

Signals with 3 LEDs (Tomar Industries, Oregon Rail Supply, all BLMA, etc)

To select signals using 3 individual LEDs (**this INCLUDES searchlight signals from BLMA and the newer searchlight signals from Tomar**) you must have a jumper covering only the center pin on the "HUE" block on the circuit board. This is illustrated in Figure 4. In addition, a jumper must only cover one pin (it doesn't matter which one) on the "block" labeled "SIG" also shown in Figure 4. The *Signal Animator* directly controls 3-light LED signals wired in a common-anode (the anode is the positive side of the LED) arrangement. Virtually all brands of 3-light signals are wired this way. A known exception is Integrated Signal Systems which typically wires their signals in a common-cathode arrangement. We offer the *Signal Animator* model SAD-CC for controlling this type of signal wiring.

You **MUST** use resistors with LED-based signals! Because the *Signal Animator* provides +5V power to the LED we recommend a resistor value of 150 ohms. We have included three resistors with this product. Since only one LED will be illuminated at a time you can choose to use a single resistor in the common anode path or individual resistors in each of the LED cathode paths. The individual resistor scheme is illustrated in Figure 5.

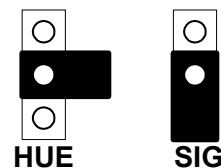

Figure 4 –selecting 3-light signals

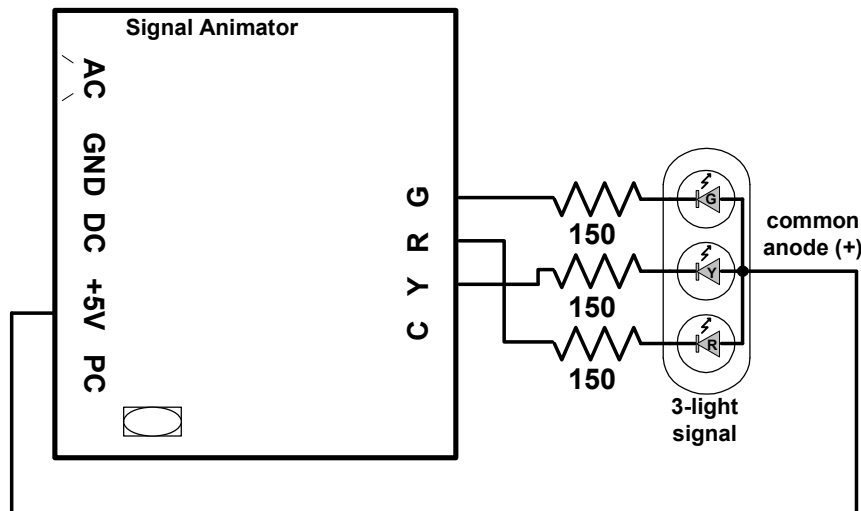

Figure 5 – 3-light signal

Mounting and wiring the IR components

The IR components should be mounted between the rails. Drill two 1 1/64" holes, through the ballast, roadbed, and sub-roadbed. These holes should be located one tie apart (Figure 6a) and drilled at approximately a 45 to 60 degree angle from horizontal as illustrated in the side view in Figure 6b. The benefit of mounting them at an angle is reduced false triggering from overhead light and increased detection reliability in smaller scales or irregular bottoms on rolling stock. For the smaller scales this drilling may end up hitting the ties. Take your time so you don't mangle them! Insert the leads of one IR emitter (white and black wires) into one of the holes (it doesn't matter which one!) from the top of your layout. Repeat for the IR detector (blue and black wires). The tops of the components should sit no higher than the top of your ballast for optimal IR performance; in some cases (e.g. false triggering) it may be necessary to locate the components a little below the ballast line. You can extend the leads with similar (or larger) wire. We recommend soldering and insulating these connections. We also recommend using terminal blocks/strips since you'll have multiple DC and GND connections to make. Once you have wired the IR components and verified their operation you may wish to put a dab of white glue or silicone caulk where the wires exit the holes underneath the layout. This will help to hold the components in place; make sure you don't get any substance (e.g. ballast or glue) on the top surface of the IR components as this may prevent them from operating properly. In extreme cases where you may be getting interference from overhead lighting you can mount the IR detector in some plastic or metal tubing. You can also recess the IR detector slightly below the ties and roadbed.

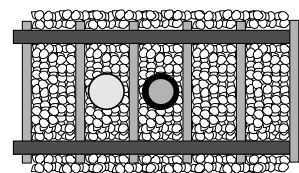

Figure 6a

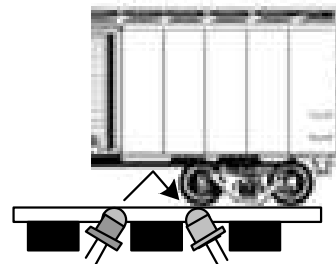

Figure 6b

Figure 7 illustrates the wiring for the IR components. The 180 ohm 1 Watt resistor (the larger one) is included with the *Signal Animator*. **WARNING: The 180 ohm 1 watt resistor may become hot to the touch – take care so that you don't burn yourself!** When properly wired the emitter will have a very faint red glow coming from it. You can also look at the emitter through a digital camera and see the infrared light! **For safety reasons do NOT point the IR emitter directly into your eye or stare at the IR emitter!!!**

NOTE: For best IR performance use a 12VDC power source OR a 9VAC power source. Do NOT exceed these ratings!!!

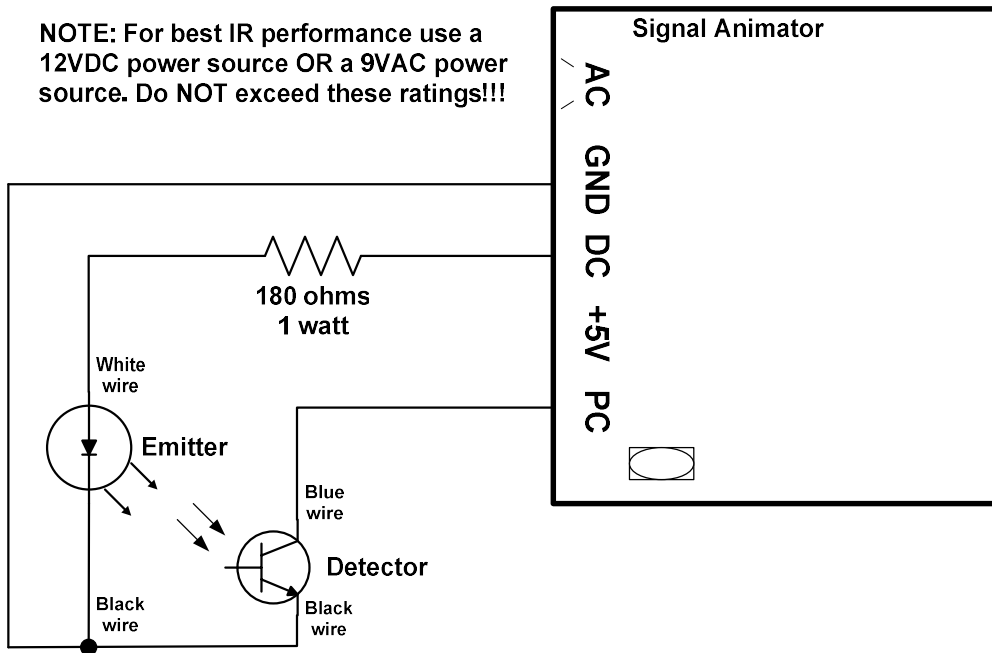

Figure 7 – IR component wiring

You can adjust the sensitivity of the IR detector by inserting a small screwdriver in the component labeled "VR1". Turning the screwdriver clockwise will increase its sensitivity. With a piece of rolling stock covering the sensor turn the VR1 fully counter-clockwise and then slowly clockwise until the signal changes to red. Then slightly turn the screwdriver a little more clockwise. Move the rolling stock away from the sensor and verify proper signal operation (delay, yellow, delay, green).

Signal delay

The signal color change delay can be either 10 seconds or 30 seconds. Choose the value based on your own personal preference. To select 10 seconds the jumper must be installed over both pins on the block "DLY"; for 30 seconds the jumper must only cover one pin (it doesn't matter which one). You can change this as you wish even when the power to the Signal Animator is on. The two options are illustrated in Figure 8.

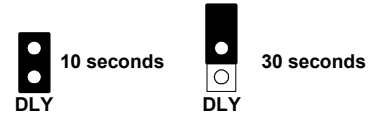

Figure 8 – signal delay

Power

The **Signal Animator** with IR requires 7-9V AC or 9-12V DC for power. Power consumption is approximately 100mA (including the signal). If you are only using a single **Signal Animator** then use the TWO AC terminals to provide power (polarity doesn't matter). CAUTION: Most AC or DC accessory terminals on your throttle/power pack exceed 12V and cannot be used with the **Signal Animator**! However, you can use those power sources in conjunction with our 12VPSR which will provide 12V DC. If you are using more than one **Signal Animator** you can power them all from a single 9-12V DC source as shown in Figure 9.

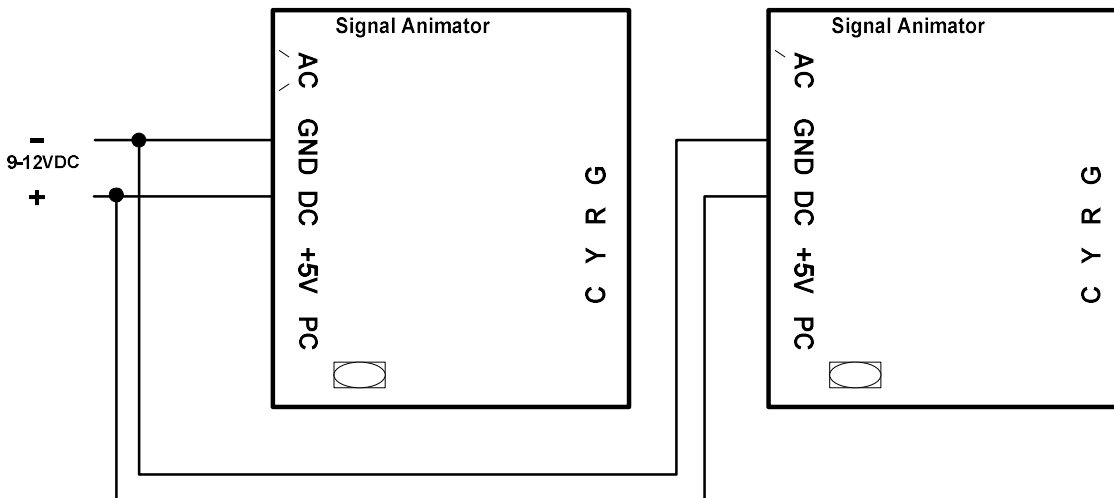

Figure 9 – DC power

Multiple signals

It is possible to use two signal heads with one *Signal Animator*. This arrangement could be used to mimic a standard block signal arrangement. The signal heads will be wired in parallel with each other (we recommend that each signal has its own resistor(s) and that the value of the resistor(s) be increased to 220 ohms) and obviously will always show the same indication. This is shown in Figure 10 below; this diagram uses 3-lead searchlight signals as an example.

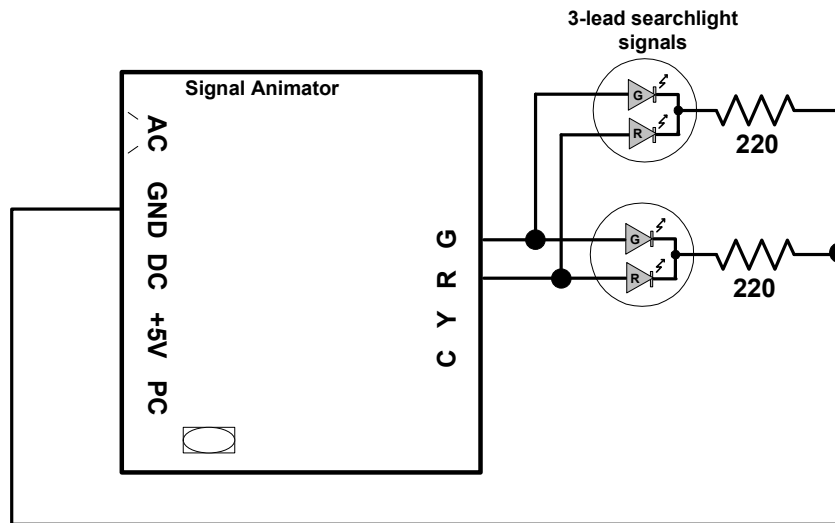

Figure 10 – Multiple signals (3-lead searchlight signal example)

Other Applications

Please contact us if you are interested in knowing how to interlock your signal (i.e. force it to red) with the position of a turnout or if you are interested in controlling a dual head signal with two *Signal Animators*. You can also access this documentation online from our website at http://www.logicrailtech.com/lrt_docs.htm

Troubleshooting

If your signal is not changing colors when the sensor is activated or stays red all the time you can perform the following tests. First, verify the sensor wiring and sensitivity adjustment previously described. If the signal stays red all the time then disconnect the sensor's blue wire. After two time delays the signal should return to green. If it does then there is a problem with the sensor. If your signal never changes from green then temporarily connect a wire between the PC terminal and the GND terminal. The signal should immediately change to red. If not, then the *Signal Animator* board should be returned to us for test/repair. If the signal did change to red then disconnect the temporary wire. The signal should proceed through its delay and color changes. If so then the problem lies with the sensor.

Warranty

This product is warranted to be free from defects in materials or workmanship for a period of one year from the date of purchase. *Logic Rail Technologies* reserves the right to repair or replace a defective product. The product must be returned to *Logic Rail Technologies* in satisfactory condition. This warranty covers all defects incurred during normal use of this product. This warranty is void under the following conditions:

- 1) If damage to the product results from mishandling or abuse.
- 2) If the product has been altered in any way (e.g. soldering).
- 3) If the current or voltage limitations of the product have been exceeded.

Requests for warranty service must include a dated proof of purchase, a written description of the problem, and return shipping and handling (\$6.50 inside U.S./\$15.00 outside U.S. - U.S. funds only). Except as written above, no other warranty or guarantee, either expressed or implied by any other person, firm or corporation, applies to this product.

Technical Support

We hope the preceding instructions are sufficient for answering any questions you might have about the installation of this product. However, technical support is available should you need it. We would ask that you first contact your place of purchase for assistance. If you still need further assistance then please do not hesitate to contact us. You can reach us via phone, mail and email; our contact information can be found on the top of page 1.