

## Introduction

This application note describes how to use current-sensing track occupancy detectors instead of the *Block Animator's* (BA) optical detection that uses photocells. You might choose current-sensing detectors in order to utilize existing occupancy detection circuits you already have in place or in order to operate in dark conditions and don't wish to use infrared detection. There is a wide selection of commercially-available current-sensing track occupancy detectors that could be used in this application. Specific details on wiring these detectors to your track are NOT provided here; refer to the instructions that come with the detector! This application note does not provide details on wiring your block signals nor does it cover power connections – these details are provided in the BA instructions!

The block signal "zone" will be broken up into three detection sections. There is an "approach" section on each side of the signal pair and a small section where the signals are located. This is illustrated below.

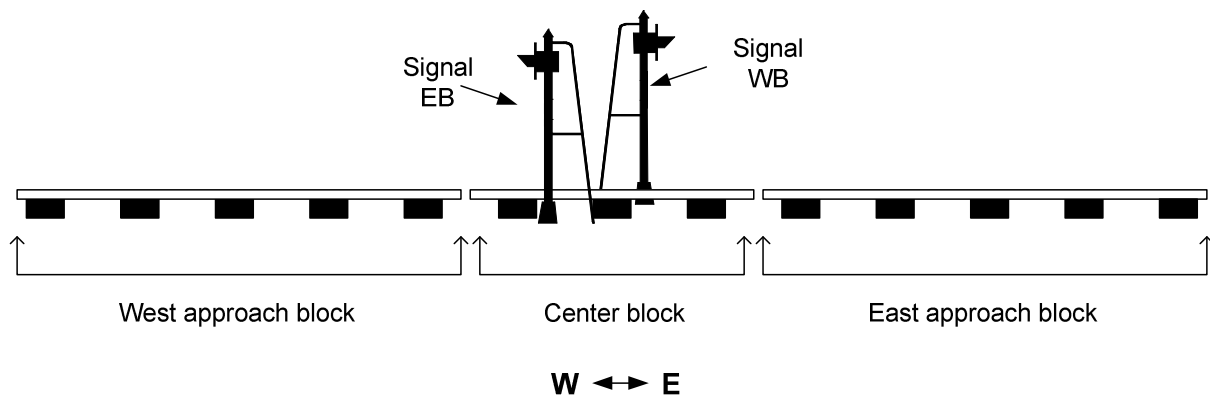

## Detector outputs

The majority of commercially-available current-sensing track occupancy detectors have an open-collector type of output. This means that when the track section is occupied the detector output will be "low" which means it will be close to 0 volts; when the track section is unoccupied the detect output will be "floating" which means it will look like an open circuit.

If your BA came with photocells then you will need to add an "inverter circuit" to "correct" the polarity difference between the detector output and the BA's photocell inputs. This is necessary due to the nature of the BA's photocell inputs. A covered photocell (i.e. very high resistance) is detected like an open circuit while an uncovered photocell (i.e. low resistance) is detected as close to 0 volts. The inexpensive inverter circuit consists of a 10K ohm resistor (e.g. Radio Shack #271-1335) and an NPN transistor (e.g. Radio Shack #276-2058 or 276-2009).

The West approach section is associated with the W1 sensor input whereas the East approach section is associated with the E1 sensor input. The center block section is associated with BOTH the W2 and E2 sensor inputs. The wiring for generic current-sensing track occupancy detectors is shown in the following figures. Note that a connection must be made between the detector's ground (GND) and the BA's GND terminal in addition to the detector output.

Figure 1 illustrates the wiring for a BA that came with photocells. Figure 2 illustrates the wiring for a BA that came with infrared components (note that the inverter circuit is not needed!).

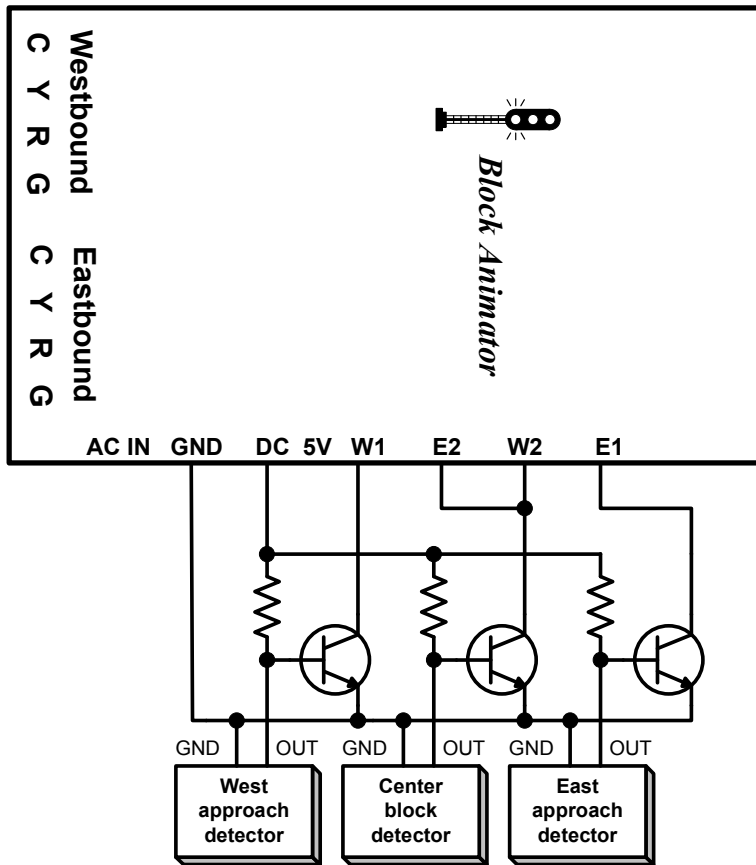

Figure 1 – Wiring for a BA that came with photocells

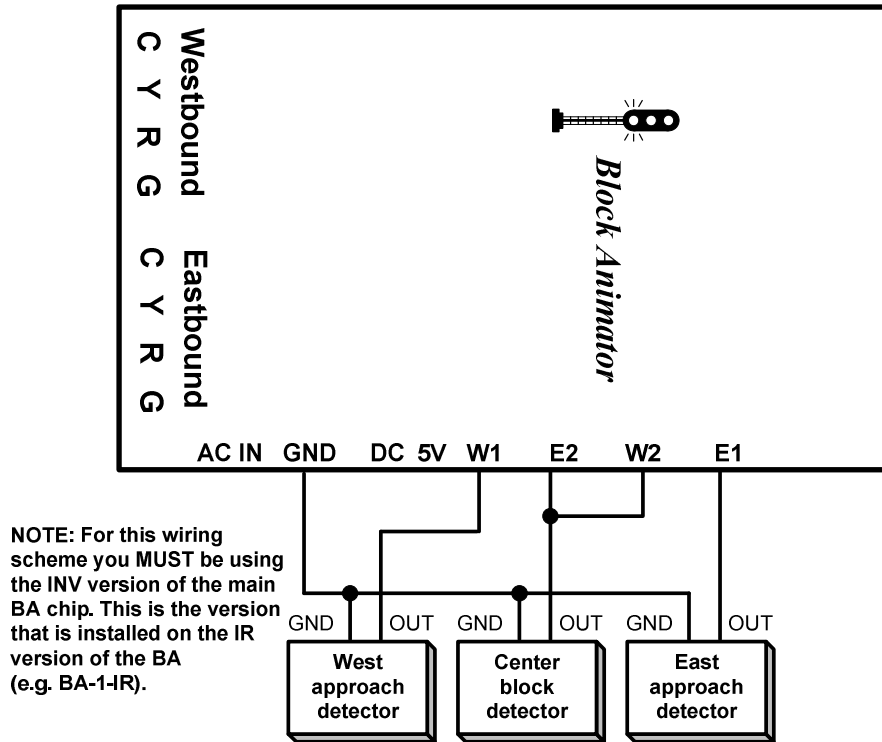

Figure 2 – Wiring for a BA that came with infrared components

## Photocell sensitivity setup

Each of the BA's four sensor sensitivity adjustment potentiometers must be set to the "midway" point. This is easily accomplished by using the procedure detailed below.

1. You must have the BA switch labeled SETUP in the ON/CLOSED position.
2. Insert the blade of a flat-blade screwdriver (from the edge of the circuit board, not from the center of the board) into the adjustment pots, one at a time. Turn the screwdriver completely **counter-clockwise** in each of the adjustment pots. Note the position/orientation of the screwdriver.
3. Rotate each potentiometer fully **clockwise** and note the position/orientation of the screwdriver.
4. Now rotate each potentiometer **counter-clockwise** until the screwdriver is approximately half-way between fully clockwise and fully counter-clockwise.
5. Place the SETUP switch in the OFF/OPEN position.

## Technical Support

If you need further assistance with this application please do not hesitate to contact us by phone, mail and email; our contact information can be found on the top of Page 1.