

**Getting started**

Thank you for purchasing a *Logic Rail Technologies* product! Please familiarize yourself with all the instructions prior to installing this board. This version of the *Block Animator* (model BA-2) provides 3-color signaling for LED-based searchlight-style signals constructed with either three individual LEDs (such as those from BLMA and NJ International) wired with a common anode or a single, bipolar (red/green) LED (such as those from Tomar and Oregon Rail Supply). This version of the *Block Animator* also includes our *TrueLens2* feature. This feature reproduces the “bounce” of the prototype searchlight signal mechanism which briefly flashes red when transitioning from yellow to green.

The *Block Animator* (BA) provides automatic operation of two 3-color block signals in a semi-prototypical way. Four pairs of Infrared (IR) emitters and detectors are used for bidirectional train detection. Detection is achieved when the IR beam from the emitter reflects off the underside of the train back down to the detector. **Despite the use of infrared components you could still encounter false triggering from overhead lighting. This is usually eliminated with angled sensor mounting and/or proper sensor sensitivity adjustment (page 4). This version of the BA must be powered from either a 7-9V AC or 9-12V DC power source (such as our 12VPSR). Do NOT exceed these limits!** The layout of the signals and IR components is illustrated at left below; the illustration on the right is a side view of the IR detection method.

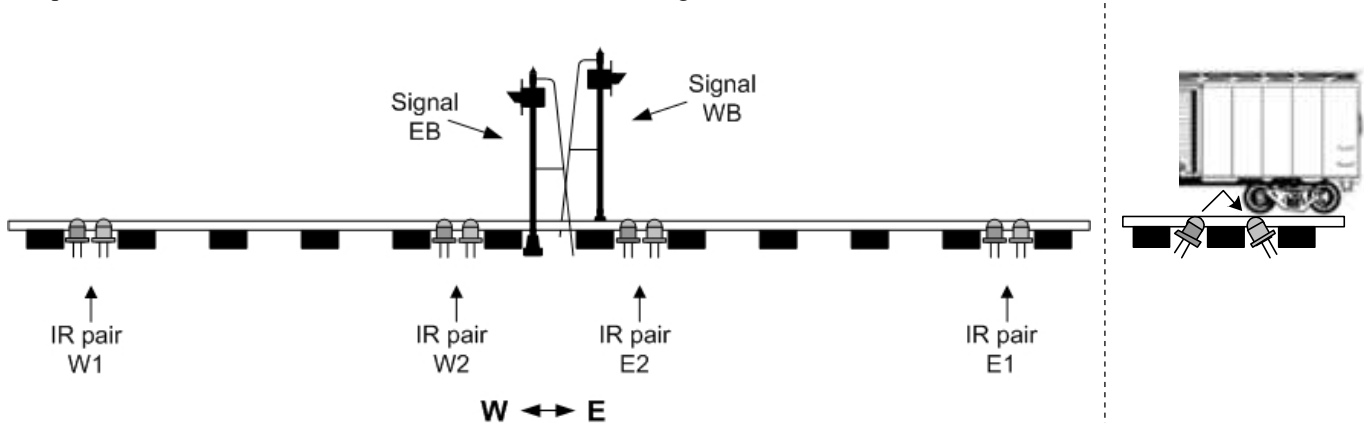

The BA operates the signals as described next. In the absence of any trains the two signals will be green. Now consider a train traveling eastbound. When sensor W1 is activated signal WB will change from green to red and will remain red as the train continues eastbound and subsequently activates sensor W2. When the train then activates sensor E2 signal EB will change from green to red. Once the train has totally cleared sensors W1 and W2 then signal WB will change from red back to green. As the train continues eastbound towards sensor E1 signal EB will remain red. Once the train has passed over sensor E1 and totally clears both it and sensor E2 signal EB will change to yellow; this mimics the behavior of the train entering the “next block.” After a time delay (10 or 30 seconds; see below) signal EB will change to green (at this transition you will see the *TrueLens2* feature). Signal operation for a westbound train is similar with signal EB changing from green to red and back to green while signal WB changes from green to red to yellow and back to green.

You should make all of the connections to the BA before applying power to it. You can mount the BA anywhere it is convenient underneath your layout using the four mounting holes provided. The holes will accept #4 screws; do not enlarge the holes as damage to the circuit board can result and your warranty will be voided!

The BA board has a set of 6 configuration switches on it. Each switch is described below.

Switch Name	Meaning when OFF/OPEN	Meaning when ON/CLOSED
SETUP	BA is in normal operating mode	BA is in sensor setup mode
DELAY	Yellow to Green delay is 30 seconds	Yellow to Green delay is 10 seconds
SIG EB	EB signal is a 3-color type	EB signal is a searchlight type
SIG WB	WB signal is a 3-color type	WB signal is a searchlight type
YELHUE	Yellow hue for bipolar LEDs is more reddish	Yellow hue for bipolar LEDs is more greenish
APPRL	Approach Lighting is Disabled	Approach Lighting is Enabled

**Approach Lighting**

The concept of Approach Lighting is quite simple. A signal remains dark (not illuminated) until a train approaches it (i.e. the block in advance of the signal is occupied). This has been primarily used in the western U.S. in remote locations where signal equipment operates on battery power. Having the signals unlit most of the time saves battery power as well as prolongs the life of the bulbs. The “rule” for illumination is simple: the signal shall be illuminated when the preceding block is occupied. The BA supports this feature (when the APPRL switch is ON/CLOSED) and works as follows. Signal EB will be illuminated

whenever an eastbound train activates sensor W1 and will keep signal EB illuminated until sensor E2 is activated and then subsequently cleared. Note that if the eastbound train activates and then clears sensor W1 but after 35 seconds hasn't activated sensor E2, then the **BA** will assume the train has actually reversed direction and will turn the signal off. Similarly, signal EB will also be illuminated whenever a westbound train activates sensor E2 and will keep signal EB illuminated until sensor W1 is activated and then subsequently cleared. The same 35 second "timeout" mechanism is in effect for this direction of travel too. Signal WB will operate in a similar manner with respect to sensors E1 and W2. You can turn approach lighting on or off at any time. Hopefully it is obvious that if you turn this feature off then the signals will be illuminated all the time!

**2-lead/3-lead LED Searchlight Signals (older Tomar Industries, Oregon Rail Supply, etc)**

To select a searchlight signal construction with a single bipolar LED on the **BA** you must turn ON/CLOSE the appropriate configuration switch. This type of LED has two elements inside of a single housing; one element is green and the other is red. There are two ways that these LEDs are internally wired. One has two leads and the other has three leads; the three-leaded variety is the most common. The **BA** supports either one as shown in Figures 1a & 1b; these diagrams depict the wiring for the Eastbound signal head; wiring for the Westbound signal head is equivalent. You **MUST** use resistors with LED-based signals! Because the **BA** provides +5V power to the LED we recommend a resistor value of 150 ohms. We have included six resistors with this product; you will not use all of them for this type of signal. With a three-leaded variety you can choose to use one resistor in the common path (as shown in Figure 1b) or you could choose to use one resistor in EACH of the color (i.e. G & R) connections (this is NOT illustrated). **NOTE: The Y and C terminals are not used with this signal type!**

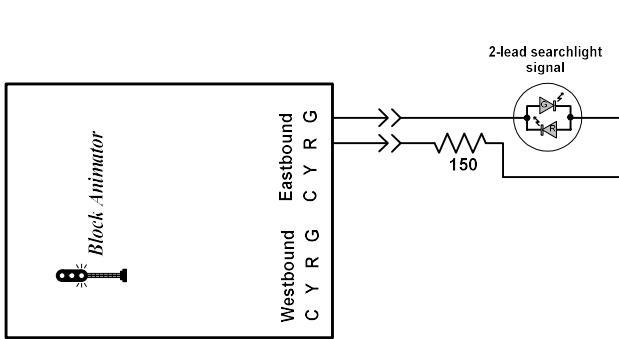

Figure 1a – two-lead bipolar

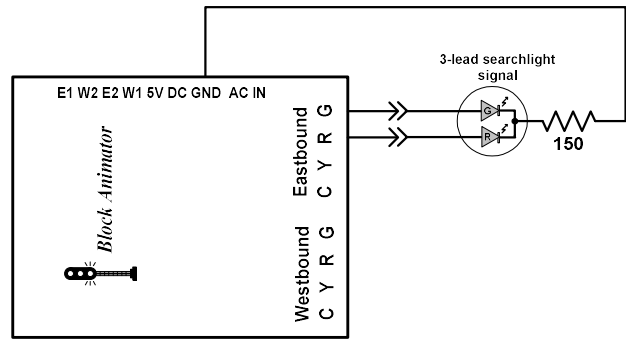

Figure 1b – three-lead bipolar

You can adjust the yellow hue on the signal(s) using the configuration switch labeled YELHUE on the circuit board. If the switch is ON/CLOSED then the yellow hue will be more greenish and less red; if the switch is OFF/OPEN then the yellow hue will be more reddish and less green.

**Searchlight Signals with 3 LEDs (BLMA, newer Tomar, NJ International)**

To select a signal constructed with 3 individual LEDs you must have the appropriate switch in the OFF/OPEN position. The **BA** controls this type of signal wired with a common anode (the anode is the positive side of the LED). You **MUST** use resistors with LED-based signals! Because the **BA** provides +5V power to the LEDs we recommend a resistor value of 150 ohms. We have included six resistors with this product. Since only one LED will be illuminated at a time you can choose to use a single resistor in the common anode path. However we recommend using individual resistors in each of the LED cathode paths as illustrated in Figure 2. **NOTE: The C terminal is not used with this signal type!**

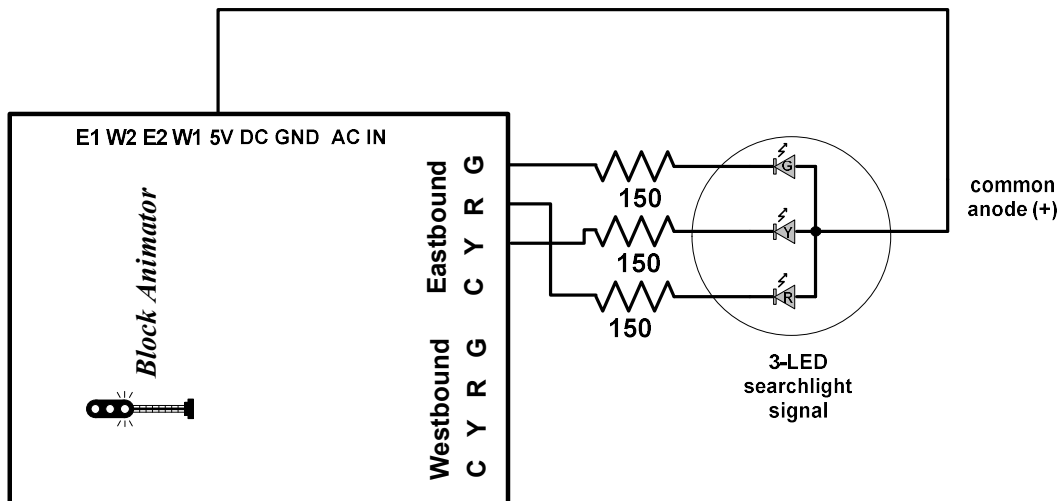

Figure 2 – 3-LED searchlight signal

## Mounting and wiring the IR components

The IR components should be mounted between the rails. Drill two 11/64" holes, through the ballast, roadbed, and sub-roadbed. These holes should be located one tie apart (Figure 3a) and drilled at approximately a 45 to 60 degree angle from horizontal as illustrated in the side view in Figure 3b. The benefit of mounting them at an angle is reduced false triggering from overhead light and increased detection reliability in smaller scales or irregular bottoms on rolling stock. For the smaller scales this drilling may end up hitting the ties. Take your time so you don't mangle them! Insert the leads of one IR emitter (white and black wires) into one of the holes (it doesn't matter which one!) from the top of your layout. Repeat for the IR detector (blue and black wires). The tops of the components should sit no higher than the top of your ballast for optimal IR performance; in some cases (e.g. false triggering) it may be necessary to locate the components a little below the ballast line. You can extend the leads with similar (or larger) wire. We recommend soldering and insulating these connections. We also recommend using terminal blocks/strips since you'll have multiple DC and GND connections to make. Once you have wired the IR components and verified their operation you may wish to put a dab of white glue or silicone caulk where the wires exit the holes underneath the layout. This will help to hold the components in place; make sure you don't get any substance (e.g. ballast or glue) on the top surface of the IR components as this may prevent them from operating properly. In extreme cases where you may be getting interference from overhead lighting you can mount the IR detector in some plastic or metal tubing. You can also recess the IR detector slightly below the ties and roadbed.

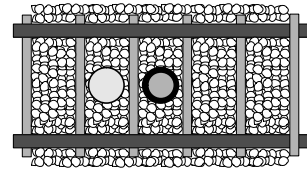

Figure 3a

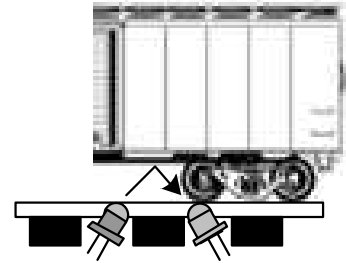

Figure 3b

Figure 4 below illustrates the wiring for one set of IR components (shown for sensor location "E1"). Replicate the same wiring for the three remaining sensor inputs. Four 180 ohm 1 Watt resistors are included with the BA. **WARNING: The 180 ohm 1 watt resistor may become hot to the touch – take care so that you don't burn yourself!** When properly wired the emitter will have a very faint red glow coming from it. You can also look at the emitter through a digital camera and see the infrared light! **For safety reasons do NOT point the IR emitter directly into your eye or stare at the IR emitter!!!**

**NOTE: For best IR performance use a 12VDC power source OR a 9VAC power source. Do NOT exceed these ratings!!!**

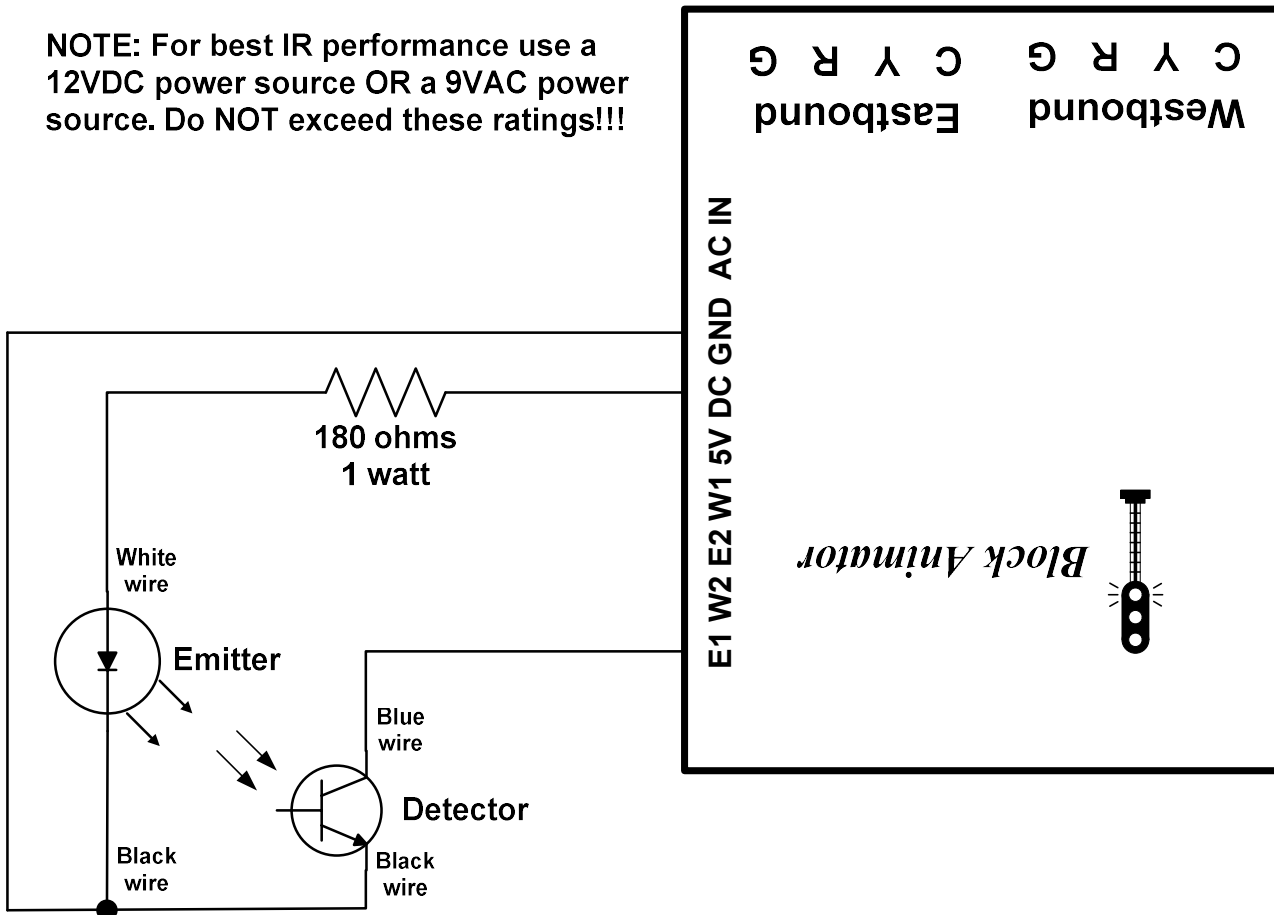

Figure 4 – IR component wiring

## Sensor sensitivity setup

You can adjust the sensitivity of each IR detector on the circuit board using a small slotted head screwdriver. Along one edge of the board are four potentiometers (or “pots”) that are labeled “W1”, “E2”, “W2” or “E1”. The **BA** supports a SETUP mode to make this adjustment process easier. To enable this mode, you must have the switch labeled SETUP in the ON/CLOSED position. In this mode the signals will not change colors. The **BA** circuit board contains a red LED near the configuration switches; this LED will assist you in setting the sensor sensitivity. Now follow these steps:

1. Remove all obstacles that may be covering the sensors.
2. Turn all four adjustment pots fully clockwise and verify that the red LED is off.
3. Place a piece of rolling stock over sensor W1. Insert the blade of the screwdriver (from the edge of the circuit board, not from the center of the board) into the W1 adjustment pot. Turn the screwdriver counter-clockwise (left) until the red LED turns on.
4. Move the rolling stock away from sensor W1 and verify that the red LED turns off. If it stays on then turn the screwdriver slightly clockwise (right) until the red LED turns off. Verify that when the rolling stock covers sensor W1 the red LED still turns on. Turning the adjustment pot more counter-clockwise increases the vertical range of detection.
5. Repeat steps 3-4 for the three remaining pots.
6. Exit SETUP mode by putting the SETUP switch in the OFF/OPEN position. The crossing signals should now operate properly. You may wish to repeat this procedure with any other layout lighting conditions you operate under (e.g. “daytime” vs. “nighttime”).

## Signal delay

The signal color delay (when the signal changes from yellow to green) can be either 10 seconds or 30 seconds. Choose the value based on your own personal preference. To select 10 seconds the configuration switch labeled DELAY must be ON/CLOSED; for 30 seconds the switch must be OFF/OPEN. You can change this as you wish even when the power to the **BA** is on.

## Power

The **BA** accepts 7-9V AC or 9-12V DC power. Power consumption for LED signals is approximately 360mA (including the signals). If you are only using a single **BA** then use the TWO AC terminals to provide power (polarity doesn't matter).

CAUTION: Most AC or DC accessory terminals on your throttle/power pack exceed 12V and cannot be used with the **BA**! However, you can use those power sources in conjunction with our 12VPSR which will provide 12V DC. If you are using more than one **BA** you can power them all from a single 9-12V DC source as shown in Figure 5 below.

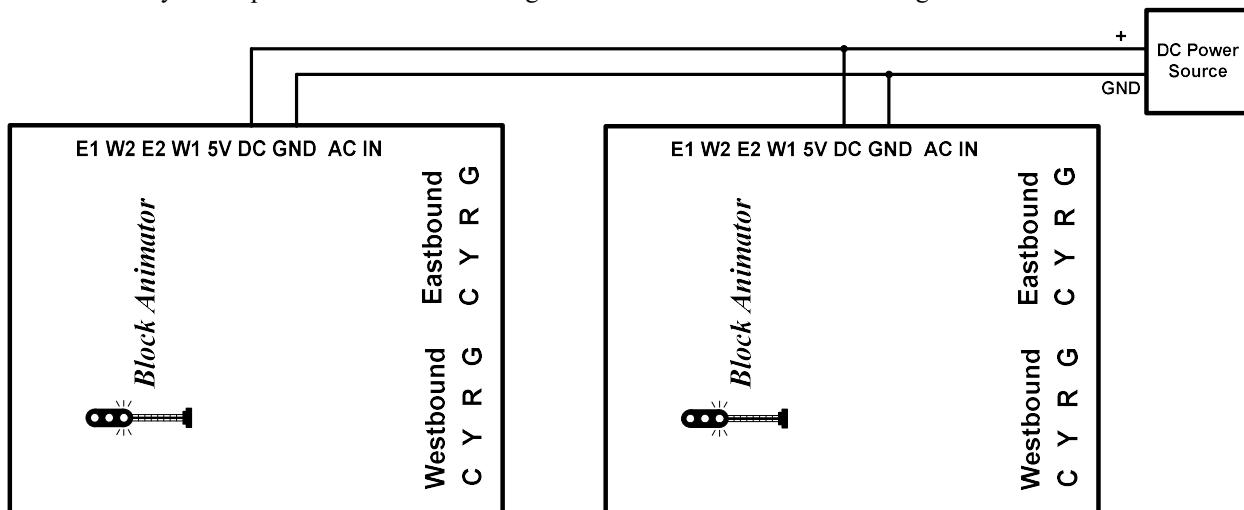

Figure 5 – DC power

## Other Applications

Please contact us if you are interested in knowing how to interlock your signal (i.e. force it to red) with the position of a turnout or if you are interested in controlling a dual head signal with two *Block Animators*. We have an instruction supplement that covers these applications as well as illustrates use of the *Block Animator* with the signals arranged as opposite ends of a long section of track. You can also access this documentation online from our website at [http://www.logicrailtech.com/lrt\\_docs.htm](http://www.logicrailtech.com/lrt_docs.htm).

## Troubleshooting

If you're using a signal constructed with a bipolar LED and the signal is red when you think it should be green and vice versa then you probably just need to reverse the R and G connections.

If your signals do not change when a particular sensor is activated then you can perform the following tests. First, perform the sensor setup routine previously described. If one or more of the sensors does not function properly then you know it is faulty. If the sensors are OK then you might have a problem with the **BA**, the signals, or the wiring between them.

If the red LED on the **BA** board stays lit when the **BA** is in SETUP mode then there is a problem with: sensor sensitivity, sensor wiring, or one of the chips on the **BA**. First, double-check your sensor wiring. A missing sensor connection (missing wire or open circuit) will be interpreted by the **BA** as a cleared sensor. A shorted sensor (i.e. blue and black wires touching) will be interpreted by the **BA** as an activated sensor. Next, put the **BA** in SETUP mode (see page 1) and turn all four sensor sensitivity pots completely counter-clockwise (left). If the red LED goes out then simply complete the sensor setup process continuing with Step 3 on page 4. If the red LED is still lit then the problem is either a bad sensor or a faulty chip on the **BA**.

You can determine if the **BA** sensing chip is working correctly by TEMPORARILY disconnecting all blue sensor wires from the **BA**. If the red LED on the **BA** is lit then its sensing chip is faulty (read on below for details on replacing it). If, on the other hand, the red LED on the **BA** is now dark then connect each sensor input (E1, W2, E2, W1) to GND, ONE sensor input at a time. An activated sensor appears to the **BA** like a connection to GND so you are, in effect, mimicking an activated sensor with this test. If the red LED does NOT come on each time you make that temporary connection (make sure you try all four sensor inputs!) then you have a faulty chip.

The chip that "processes" the sensor inputs is located closest to the sensor sensitivity pots. This chip is labeled "LM339". Replacements are available from us or you can purchase one from stores such as Radio Shack (part number 276-1712). To replace the chip you will need to gently pry it out of its socket using a flat blade screwdriver. Take great care when inserting the replacement chip so that you don't bend any of its pins underneath it. Make sure the text on the chip has the OPPOSITE orientation as the name "Block Animator" on the circuit board.

## Warranty

This product is warranted to be free from defects in materials or workmanship for a period of one year from the date of purchase. **Logic Rail Technologies** reserves the right to repair or replace a defective product. The product must be returned to **Logic Rail Technologies** in satisfactory condition. This warranty covers all defects incurred during normal use of this product. This warranty is void under the following conditions:

- 1) If damage to the product results from mishandling or abuse.
- 2) If the product has been altered in any way (e.g. soldering).
- 3) If the current or voltage limitations of the product have been exceeded.

Requests for warranty service must include a dated proof of purchase, a written description of the problem, and return shipping and handling (\$6.50 inside U.S./\$15.00 outside U.S. - U.S. funds only). Except as written above, no other warranty or guarantee, either expressed or implied by any other person, firm or corporation, applies to this product.

## Technical Support

We hope the preceding instructions are sufficient for answering any questions you might have about the installation of this product. However, technical support is available should you need it. We would ask that you first contact your place of purchase for assistance. If you still need further assistance then please do not hesitate to contact us. You can reach us via phone, mail and email; our contact information can be found on the top of page 1.